

ORBITAL Engine Production /Sales

Investment Proposal

High Level Overview:

It is high power output engine that is less than a quarter in size and weight of a traditional equivalent Piston engine.

The Product

The company will launch a 10kVA Power Generator Product ('Genset') powered by a 150S ORBITAL engine. The UK is the World Market Leader in Gensets with mature, established distribution routes.

Funds Required

The company seeking to raise **£2 million**, by means of an equity investment, in order to take immediate advantage of the Global opportunities for the Orbital Genset.

Management

The Company has an experienced Management Team to oversee the development and running of The Company.

Production

The Production of Orbital's Gensets will be outsourced locally within the UK.

Sales and Routes to Market

As the Market for Gensets is well established and expanding Worldwide, the Company's route to Market will be via agents selling both in the UK and Globally.

Financial Projections

Conservative Financial Forecasts predict the company will be profitable in Year 2 culminating in Pre-Tax Profits in Year 5 of £6M.

Exit Route

An Exit Route for the Investor(s) within five years would be via a Trade Sale, IPO or an agreed multiple of Post Tax Profits.

The Product

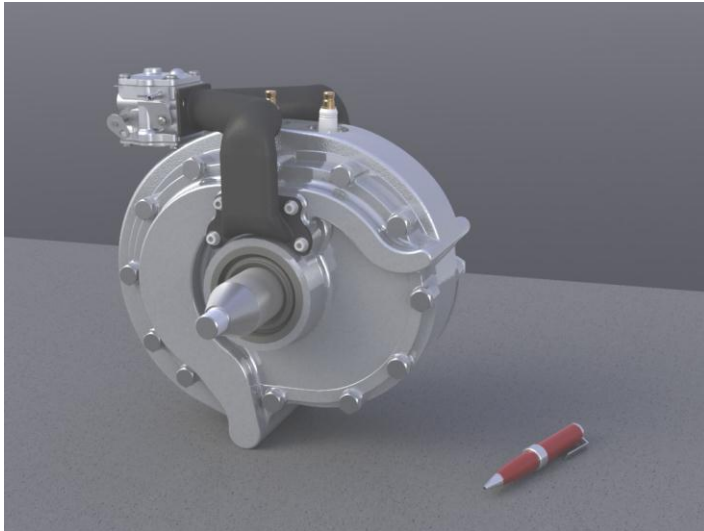

The unique ORBITAL engine design achieves the following:

- Advantageous Power to Weight Ratio
- Compact, lightweight, single person portable
- A 'Green' Product with an extremely low carbon footprint
- A low Emissions product – virtually no Hydro-Carbons produced
- A recyclable Engine
- A product which can run on a variety of fuels; namely Petrol, Diesel, Bio-fuels e.g. Ethanol and Methanol and J fuels
- Innovative use of newly refined Materials which are lightweight & have a high tensile strength
- Low maintenance costs as the engine has only three moving parts compared to a Piston engine that may have as many as 132 moving parts.
- Cost effectiveness – extremely high energy transfer efficiencies

For full details please email: enquiries@oasisinternational.co.uk